



AMT-Magnetic Mixer

AMO-Homogenizer



Sanitary
flow
equipment

AMT-Magnetic Mixer

Description

Designed complying with FDA rules for pharmaceutical and biotechnology industries. The major advantage is that enables the total integrity of the tank. The transmission with magnetic torque avoids the occurrence of cross contamination between product and external environment, a typical problem of the use of devices with mechanical seals (shafts, seals and other equipment). Suitable for high viscosities, offers great flexibility. The bottom mounting allows to keep clear the tank from any other body, such as shafts from the top and baffles, thus easing vessel access, cleaning and maintenance.

Principle of Operation

A machined pad is welded into the bottom of the vessel (usually offset respect to the central axis). This design allows to dismount the drive unit and to sterilize the tank in an autoclave, meanwhile the same drive unit can be installed and operated in another vessel. The impeller head is running by a drive unit externally mounted. Inside the impeller head there is a ring of special magnets encapsulated in a 316L ss housing. The blades are welded to this housing, creating an integral impeller head.

General information

MATERIAL WETTED PARTS

Welding plate	stainless steel AISI 316L- 1.4404 or 1.4435
Impeller	stainless steel AISI 316L- 1.4404 or 1.4435
Bearing	Tungsten Carbide, Silicon Carbide, Zirconium Oxide
O-Ring	FDA and USP Class VI

WELDING PLATE

Surface roughness	Ra<0,5 micron or better
Available on request	electro polished
Design pressure	-1 to +10 bar(g)
Design temperature	-80 to +200 °C
In compliance with	the welding plate is in compliance to PED Directive 2014/68/EU Category IV

Labelling	for full traceability purposes each welding plate is individually marked with item and heat No.
-----------	---

OPTIONAL ACCESSORIES

Speed sensor	a magnetic proximity sensor can be installed on the impeller to measure its real speed rotation
Extension	different lengths extensions available on request

ATEX execution

in compliance with the European Directive 2014/34/EU ATEX available on request



AMT Performance

The geometry of the impeller allows an excellent axial pumping flow and very low shear rate for different applications:

- mixing, dilution, maintaining in suspension...

Speed range 80 to 380 rpm using an inverter.

Depending on the size of vessel and impeller-head, levels of agitation can change from vigorous to gentle. Small volumes can be achieved.

- all product contact parts are made in 316L. The impeller head runs on a special grade bearing that has been manufactured under controlled conditions to achieve the correct size, grain structure and hardness.
- the blade shape and profile has been designed to optimize agitation levels and to direct a portion of the cleaning fluid through the head.



Warning: the assembled Mixer may have different design temperature and / or pressure limits. The weakest component in the assembled product determines the maximum design temperature and pressure limits.

WELDING
ATE



Dismounting system for magnetic coupling to take off the impeller without any magnetic attraction and without remove the motor. Dedicated for heavy, biggest size from AMT-20 to AMT-64.

Type	Volume Range Vigorous/Gentle	Motor Power rating	Weight	Impeller Diameter	Weld plate Diameter / Thickness
AMT-02-PBAM- # @ -1B	5 - 10 L	60 w - 0,08 hp	4 Kg	Ø 75 mm	Ø 60 x10 mm
AMT-04- PAAA- # @ -1B	10 - 50 L	120 w - 0,16 hp	7 Kg	Ø 105 mm	Ø 70 x10 mm
AMT-06- PAAS- # @ -1B	50 - 150 L	250 w - 0,34 hp	9 Kg	Ø 130 mm	Ø 85 x15 mm
AMT-08- PAAS- # @ -1B	150 - 500 L	0,55 kw - 0,74 hp	15 Kg	Ø 155 mm	Ø 125 x 23 mm
AMT-12- PAAS- # @ -1B	300 - 2.000 L	0,75 kw - 1,00 hp	20 Kg	Ø 175 mm	Ø 150 x 23 mm
AMT-20- PAAS- # @ -1A	1.000 - 3.000 L	1,50 kw - 2,01 hp	30 Kg	Ø 220 mm	Ø 185 x 23 mm
AMT-32- PAAS- # @ -1A	2.000 - 6.000 L	2,20 kw - 2,95 hp	45 Kg	Ø 280 mm	Ø 250 x 30 mm
AMT-64- PAAW- # @ -1A	3.000 - 20.000 L	5,50 kw - 7,38 hp	114 Kg	Ø 290 mm	Ø 278 x 30 mm

bearing combination @ bearing sealing

- The mixing capacities above are based on aqueous like products with a density of 1.000 Kg/m³ and a viscosity of 1cp.
- Typical applications for "Gentle mixing" are where solid are held in suspension or where powders easily dissolve into the liquid.
- Typical applications for "Vigorous mixing" are where a vortex is required for blending of powders into a liquid.

AMT-MAGNETIC MIXER

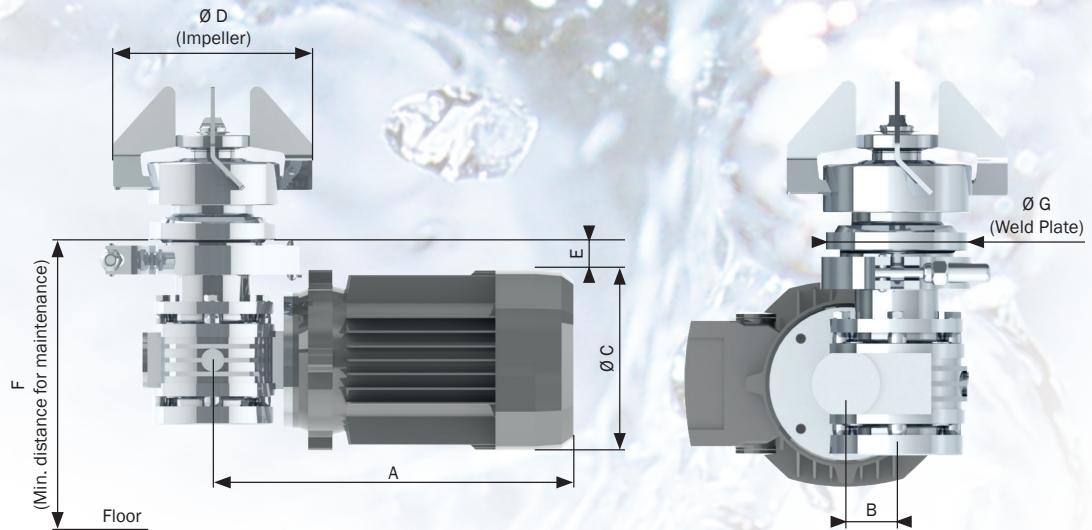

NOMINAL DIMENSIONS IN MM

Type	A mm	B mm	$\varnothing C$ motor	$\varnothing D$ impeller	E mm	F mm	$\varnothing G$ weld plate
AMT-02-AC Complete	195	28	$\varnothing 92$ mm	$\varnothing 75$ mm	16	180	$\varnothing 60$ mm
AMT-04-AC Complete	230	30	$\varnothing 110$ mm	$\varnothing 105$ mm	12	200	$\varnothing 70$ mm
AMT-06-AC Complete	235	30	$\varnothing 120$ mm	$\varnothing 130$ mm	6	200	$\varnothing 85$ mm
AMT-08-AC Complete	290	50	$\varnothing 140$ mm	$\varnothing 155$ mm	33	250	$\varnothing 125$ mm
AMT-12-AC Complete	330	63	$\varnothing 160$ mm	$\varnothing 175$ mm	38	280	$\varnothing 150$ mm
AMT-20-AC Complete	400	75	$\varnothing 175$ mm	$\varnothing 220$ mm	30	290	$\varnothing 185$ mm
AMT-32-AC Complete	400	75	$\varnothing 180$ mm	$\varnothing 280$ mm	70	350	$\varnothing 250$ mm
AMT-64-AC Complete	590	31	$\varnothing 220$ mm	$\varnothing 290$ mm	97	450	$\varnothing 278$ mm

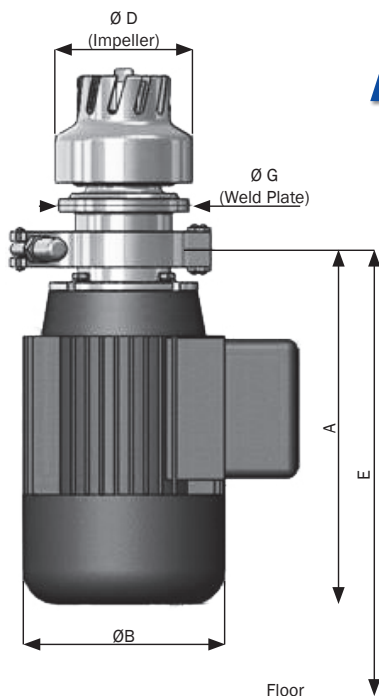

AMO-HOMOGENIZER

NOMINAL DIMENSIONS IN MM

Type	A mm	$\varnothing B$ motor	$\varnothing D$ impeller	E mm	$\varnothing G$ weld plate
AMO-04-AC Complete	235	140	78	330	70
AMO-08-AC Complete	340	175	110	400	125
AMO-20-AC Complete	470	260	165	550	185

AMO-64-AC Complete

Available on request only

AMO-Homogenizer



WELDING
TE

AMO Performance

The geometry of the rotor allows an excellent axial pumping flow and very low shear rate for different applications, especially for homogenizing, that means to transport one phase or ingredient (liquid, solid, gas) into a main continuous phase (typically liquid), with which it would normally be insoluble.

- **EMULSIFYING:** the process of dispersing one liquid into a second insoluble liquid, such as oil dispersed in water. Producing a small particle size necessary in order to achieve a stable emulsion.
- **DISSOLVING** or downsizing application, dissolving in dispersing an insoluble or semi insoluble solid into a liquid. Downsizing is often desired to reduce the particle size of the solids to obtain a stable suspension.
- **SUSPENDING** is dispersing of solid particles into a liquid.

Speed range 500 to 3000 rpm using an inverter, depending on the size of vessel and impeller head, small volumes can be achieved.

Type	Volume Range Vigorous/Gentle	Motor Power rating	Weight	Impeller Diameter	Weld plate Diameter / Thickness
AMO-04-AC	10 – 150 L	0,55 Kw – 0,75 hp	8 Kg	Ø 78 mm	Ø 70 x 10 mm
AMO-08-AC	150 – 600 L	2,20 Kw – 2,99 hp	22 Kg	Ø 110 mm	Ø 125 x 23 mm
AMO-20-AC	600 – 2500 L	7,50 Kw – 10,2 hp	55 Kg	Ø 165 mm	Ø 185 x 23 mm
AMO-64-AC	Available on request only				

- The mixing capacities above are based on aqueous like products with a density of 1.000 Kg/m³ and a viscosity of 1cp.
- AMO Homogenizer can also be combined with a standard AMT mixer to achieve a variety of powerful results, such as collapsing vortex to prevent foaming, increased agitation, maintained suspensions at low levels etc...



ASEPTIC SAMPLING VALVES



SANITARY SAMPLING VALVES



ASEPTIC SAMPLING BOTTLE



ASEPTIC TANK BOTTOM VALVES



SPRING CHECK VALVES



HIGH PURITY BALL VALVES



BUTTERFLY VALVES



DTS HEAT EXCHANGERS



SIGHT GLASS-FLOW INDICATOR



CLAMP FITTINGS



TANK AND IN-LINE CONNECTIONS



FLEXIBLE HOSES & FITTINGS



MAGNETIC MIXER



HIGH PURITY DIAPHRAGM VALVES

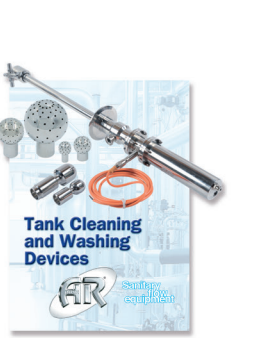

WASHING DEVICES



HYGIENIC RUPTURE DISC



Sanitary flow equipment

AERRE INOX s.r.l.
 Via Gerola, 4
 I-26010 Fiesco (Cremona)
 Tel. +39 0374 370 828 Fax +39 0374 370 833
 www.aerreinox.it

BIMEX
 Vertriebs-, Handels- und Service GmbH

Tel. +49(0)30/3670 50-90
 Fax +49(0)30/3670 50-92
 E-Mail mail@bimex-gmbh.de
 Web www.bimex-gmbh.de

Zimmerstraße 22
 D-13595 Berlin

Get the information you need and more at info@erreinox.it